

ES 200 EASY

Sliding door
operator

Flexible, Simple And Modular

The **ES 200 Easy** in the attractive DORMA design stands for simple automation of sliding door units in all areas of application. It is the innovative drive system for door units up to 2 x 100 kg, is of modular construction with world-wide tried and trusted electronics and new mechanics comprising only a few components and can be used for both 100 and 150 mm height.

Tested for 1million cycles

The prefabricated **MiniDriveUnit** is also impressive; it is tested industrially with all the necessary electrical and electronic components.

The optimum solution for all customers who value simply assembly, low storage costs and ease of maintenance.

High quality, excellent costeffectiveness

DORMA offers a particularly cost-effective sliding door operator in the tried and trusted

Features and advantages

- Modular, flexible system .. For door units up to 2 x 100 kg
- Problem-free adaptation to individual requirements
- Low number of system components .
- Industrially prefabricated and tested MiniDriveUnit
- Easy assembly of drive systems
- Multi-functional control, commissioning without programming equipment
- Easy fixing and commissioning
- Can be combined with all customary door profiles
- Reliable function and high safety standards
- Smooth movement
- Complete program at program switches
- Numerous standard connections
- Reliable investment due to compliance with all relevants European standards

Our commitment to a sustainable future

We are committed to sustainable development as one of our business maxims. DORMA's aim is to ensure energy-saving and resource-conserving production, a high recycling ratio and the longevity of our quality products. Environmental Product Declarations (EPD), based on a holistic life

DORMA quality with the new **ES 200 Easy**. The basic version of the ES 200 sliding door operator is suitable for vastly differing applications and can be combined with all customary door profiles. It offers a number of adjustment possibilities, has excellent operation characteristics and is easy to maintain.

The self-learning microprocessor controller guarantees reliable operation, ensures dynamic and smooth movements and fulfils the highest safety requirements according to all European and German standards. The setting of all parameters is carried out quickly and easily via an integrated display with push-buttons. Operation is extremely simply and menu-assisted. Additional programming equipment is not required. DORMA supplies, as the optimum supplement, program switches and pulse senders as well as door profiles specially matched to the drive.

cycle assessment, are used for the calculation of the sustainability of buildings. EPD certificates are on www.dorma.com available.



Door parameters		ES 200 Easy
1-panel sliding door	- Transit width LW - Door panel weight, max.	700 – 3000 mm 1 x 120 kg
2-panel sliding door	- Transit width LW - Door panel weight, max.	800 – 3000 mm 2 x 100 kg
Clear passage height*		2100 – 3200 mm

*Other dimensions on request.

Technical Data	
Height	100 und 150 mm
Depth	180 mm
Opening and closing force max. 150 N	●
Opening speed (incremental setting)	10 – 50 cm/s
Closing speed (incremental setting)	10 – 40 cm/s
Hold-open time	0,5 – 30 s
Mains voltage, frequency	230 V, 50/60 Hz
Power consumption	180 W
Ingress protection	IP 20
Admissible temperature	-20 to + 60 °C
Admissible humidity (relative)	max. 93 % (non condensing)
Tested according to low-voltage guidelines	●
Manufacture according to ISO 9001	●
Environmental product declaration in accordance with ISO 14025 Programme holder: Institute Construction and Environment e.V. Declaration number: EPD-DOR-2013511-E	●

Basic module (BM)	ES 200 Easy
Microprocessor controller	●
Functional programs	
- Off	●
- Automatic	●
- Permanent open	●
- Partial open	●
- Exit only	●
- Night-bank switch	●
Emergency off	●
Self-learning	●
Automatic reversing	●
Connection for bistable electro-mechanical locking	●
Connection for light barriers (max. 2 pairs)	●
Setting of basic parameters via integrated display and push-buttons	●
Emergency opening or closing (with use of battery pack)	●
24 V output for external consumption	●
Admissible humidity (relative)	●
Read-out error store with error codes	●

Additional equipment	
Electro-mechanical locking (bistable)	○
Manual unlocking for electro-mechanical locking	○
Light barriers	○
Battery pack (emergency opening, emergency closing)	○
Emergency power module USV	○

● standard ○ optional

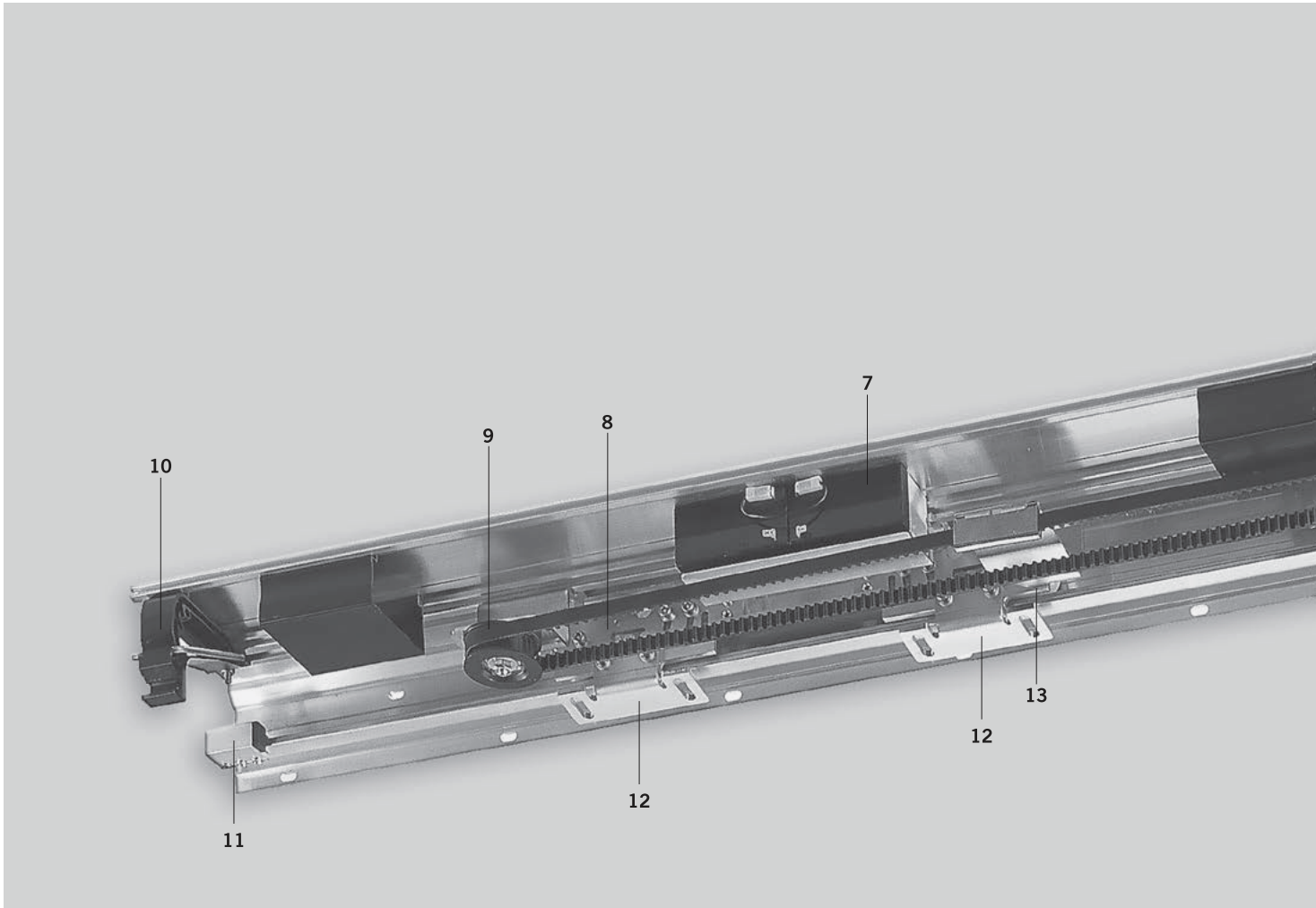

Profiles for corridor installation, 100 mm

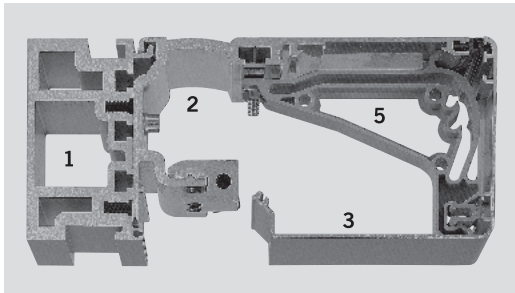

Profiles for wall fixing, 100 mm

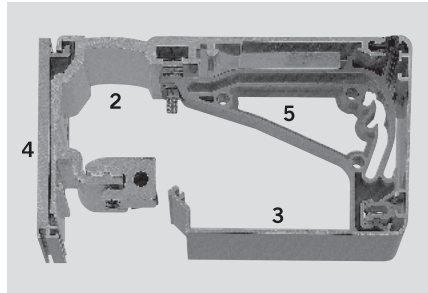

Profile for 100 mm and 150 mm height, for corridor or wall fixing guarantees adaptation for all possible applications. The mechanical basic system, with a low number of components, is the same for both heights.

Profiles for corridor installation, 150 mm

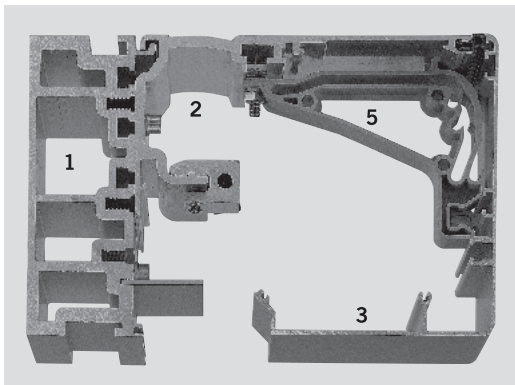

Profiles for wall fixing, 150 mm

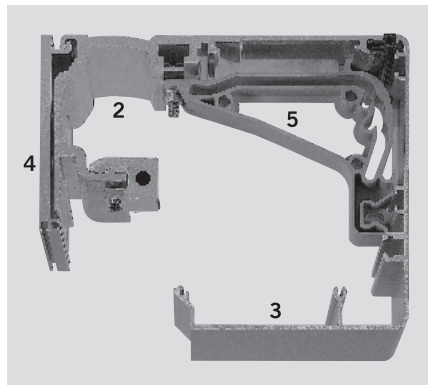

- 1 LM rail
- 2 Basic drive profile
- 3 Interior cover in 100 or 150 mm height
- 4 Wall fixing profile
- 5 Service cover holder

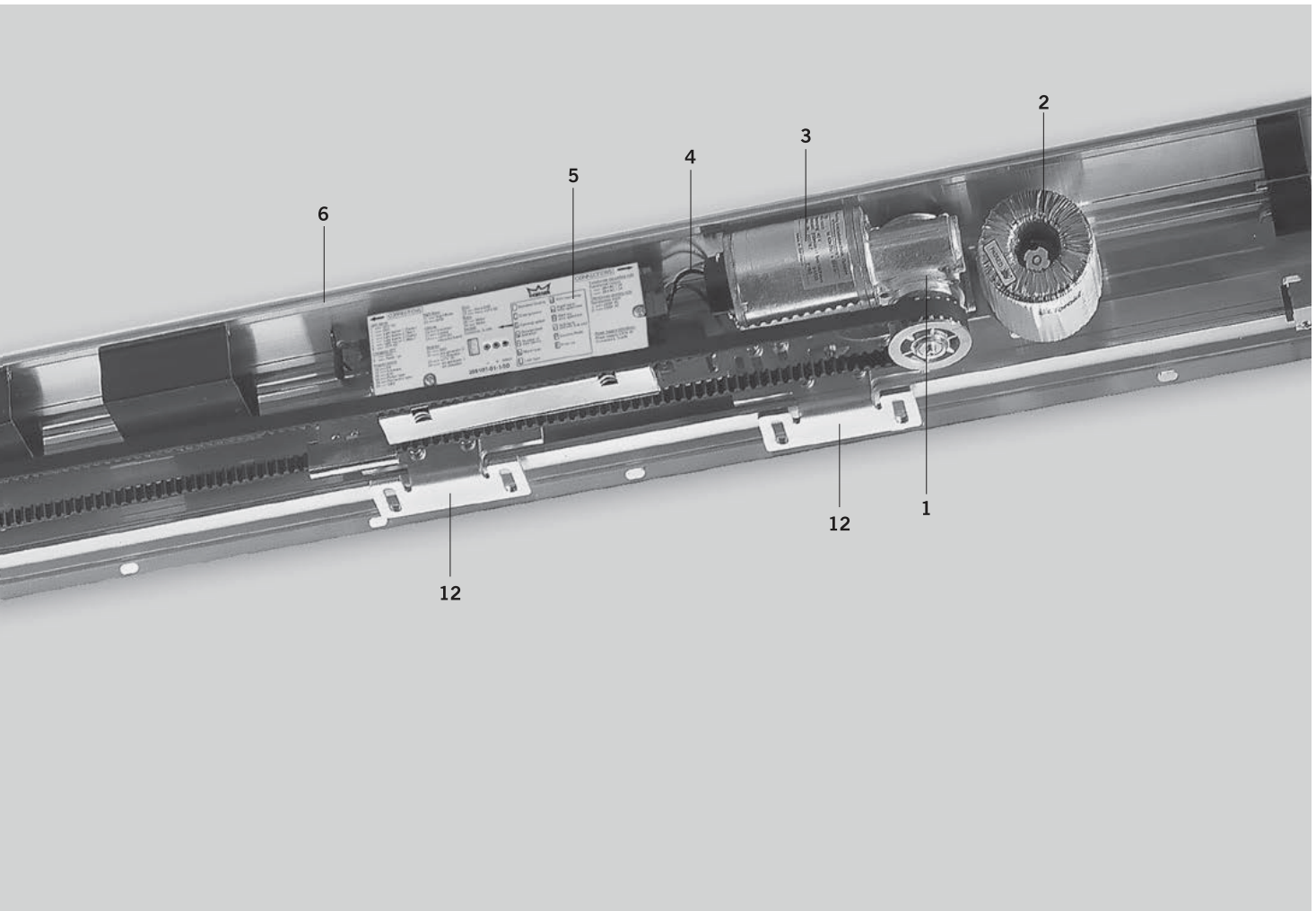

MiniDriveUnit

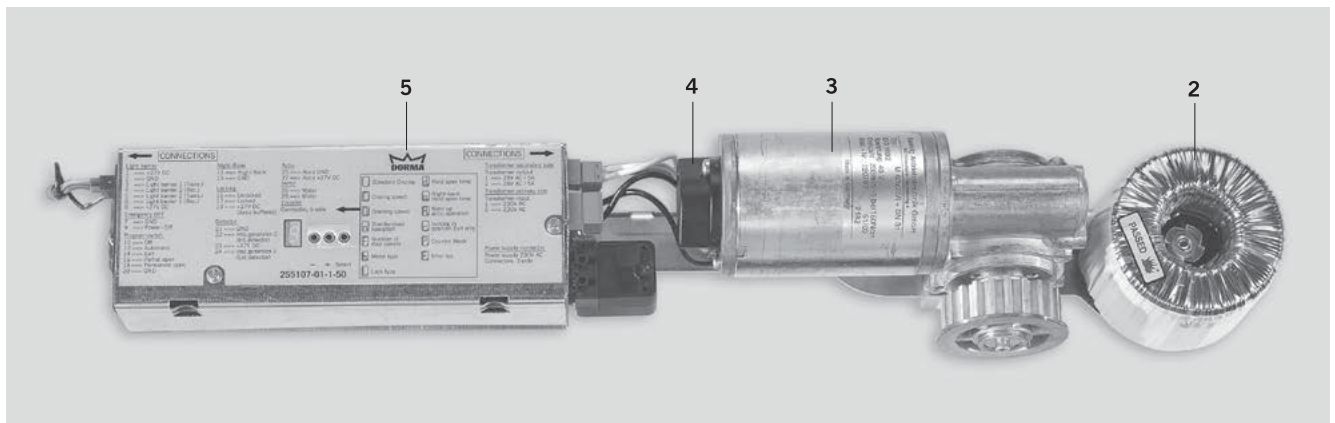

The heart of the ES 200 Easy

The prefabricated **MiniDriveUnit** with all the electrical components necessary is industrially tested and facilitates the assembly and maintenance of drive units.

The control unit has proven its worth a thousand times in all imaginable fields of application throughout the world.

Components

- 1** MiniDriveUnit
- 2** Transformer
- 3** Motor
- 4** Decoder
- 5** Control unit EC2
- 6** Run and installation profile
- 7** Battery pack (optional)
- 8** Carriage
- 9** Deflection roller
- 10** Service cover holder

- 11** End stopper
- 12** Door suspension with adjustment device
- 13** Belt connection

ES 200 Easy

the drive for individual door design

Door variants with ES 200 Easy, 100 mm height

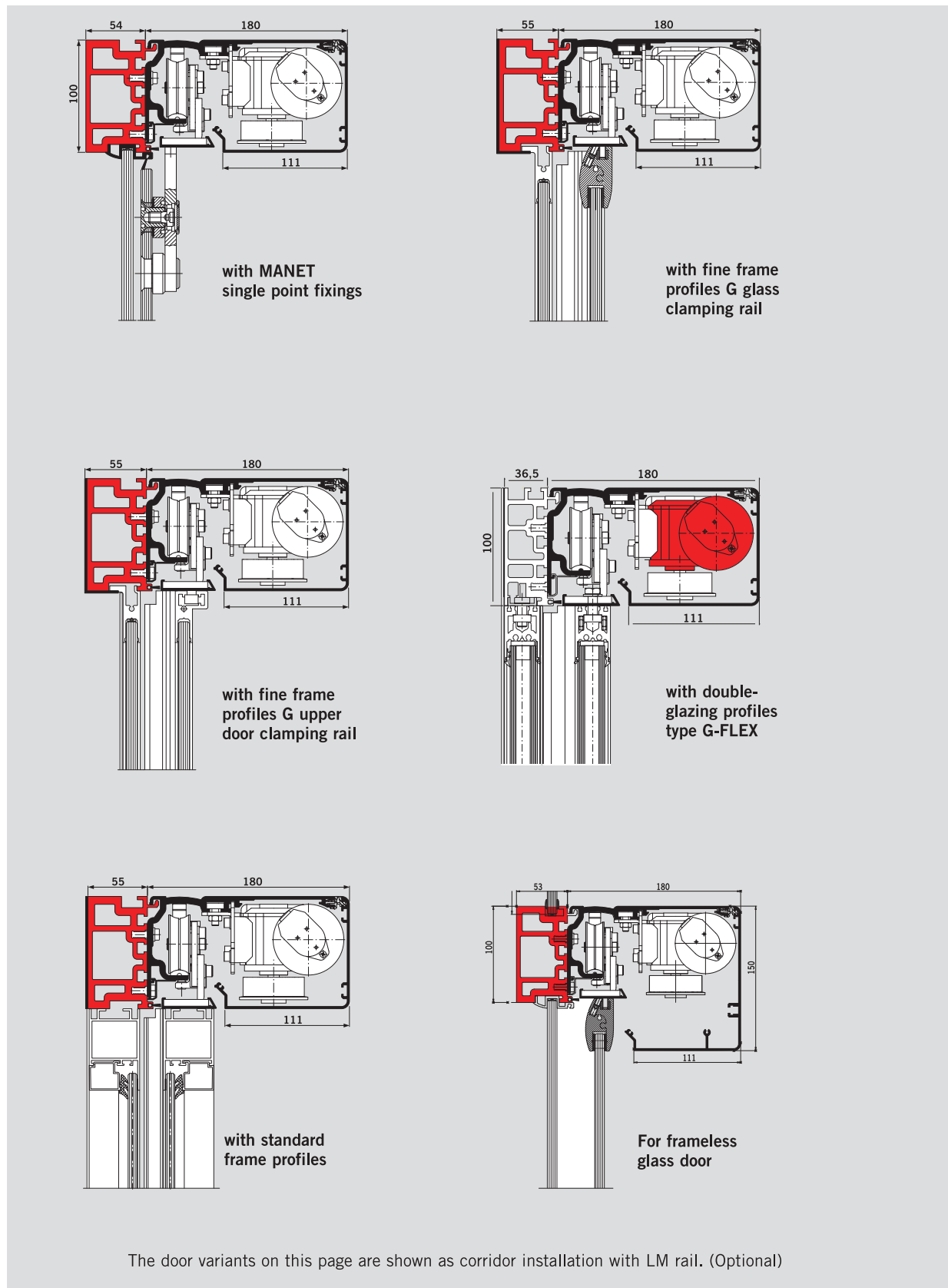

Connections

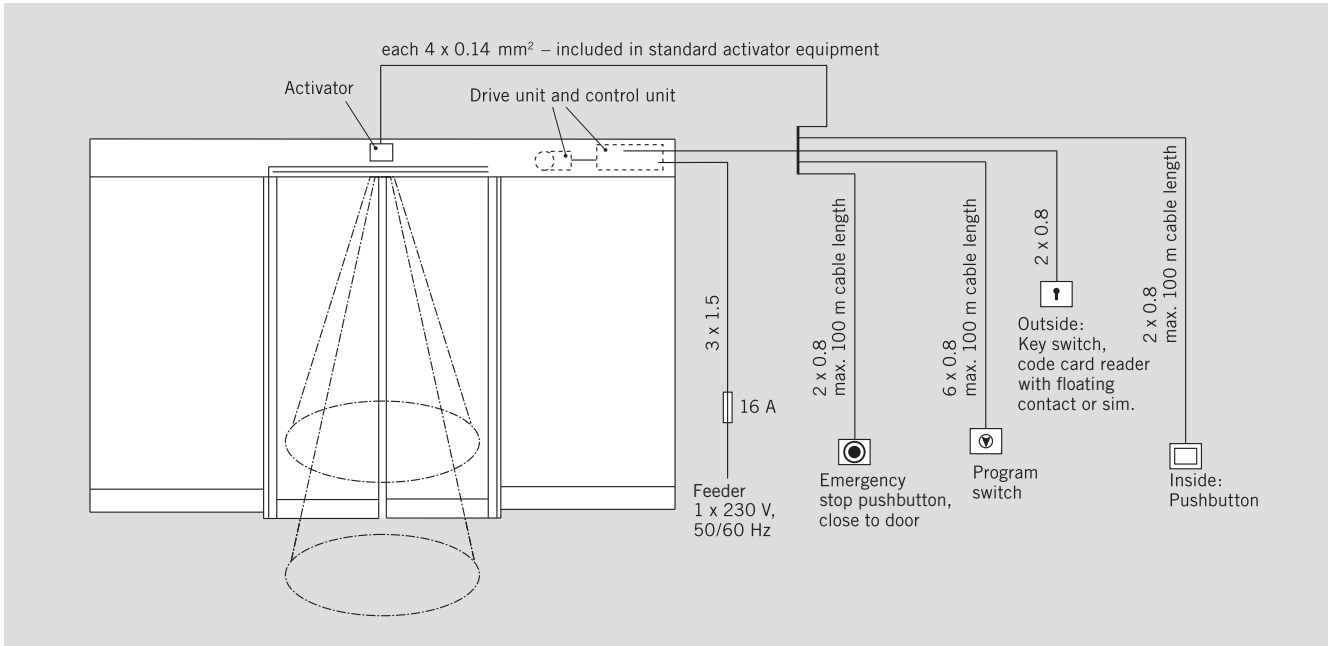



Program Switches

A program switch from DORMA's broad range of accessories allows the automatic door system to meet individual requirements and provides easy handling.



The corresponding 5-position program switches are available in various designs and suitable for all kinds of applications.

They offer various options, from a mechanical to a full-electronic version, alternatively also lockable via profile half-cylinder or in a full-electronic way via code.

- Up to 5 different functions: Off, Automatic, Exit Only, Partial Open, Permanent Open
- Electronic program switches in System 55 design to meet the highest aesthetical demands





For sliding door operators	Designation	Specification	Installation system	Order No.
	PG-S1	5-position, aluminium, white, flush-mounted version, 80 x 80 x 40 mm	Gira S-Color	19135401150
	PG-S2	5-position, lockable, aluminium, white, flush-mounted version, 80 x 80 x 40 mm	Gira S-Color	19135602150
	EPS-S	Full-electronic program switch in System 55 design, 5-position, lockable via code or additional TL-ST S55 key switch, membrane keypad aluminium-coloured, white, flush-mounted version, 80 x 80 mm	System 55	16556901150

Switches



	Designation	Specification	Installation system	Order No.
	On/Off switch	White, aluminium, flush-mounting, 80 x 80 mm	Gira S-Color	19135403150
	Magic Switch	Proximity-type radar switch responds to movement, for flush-mounting, 80 x 80 mm		05076831332

Push Button

Palm pushbutton	Designation	Specification	Installation system	Order No.
		Single-pole changeover contact, single-type frame, white, flush-mounted version	System 55	19144701170

Key switches	Designation	Specification	Installation system	Order No.
	KT 3-1	1 NO contact with profile half-cylinder, may be replaced for any profile half-cylinder of a master key system, key only retractable in neutral position, aluminium, metal, 75 x 75 x 60 mm		
	KT 3-1 UP	flush-mounted version		05054531332
	KT 3-1 AP	surface-mounted version		05054631332
	KT 8	Lettering "Auf, Zu" (German for "Open/Closed"), 2 NO contacts, with profile half-cylinder, may be replaced for any profile half-cylinder of a master key system, key only retractable in neutral position, aluminium, metal, 75 x 75 x 60 mm		
	KT 8 UP	flush-mounted version		05054831332
	KT 8 AP	surface-mounted version		05054931332
	TL-ST S55	Switch with single-pole changeover contact, for profile half-cylinder by others to DIN 18252, locking cam centre 30 – 32.5 mm, overall length 40.5 – 43,5 mm, locking cam position left (90°), incl. cover for System 55, not suitable for box for surface-mounting, not including profile half-cylinder, not including frame		
	TL-ST S55 W	White	System 55	56330710
	TL-ST S55 S	Silver-coloured	System 55	56330701
	TL-ST S55 A	Anthracite	System 55	56330715
	KT 3-2	1 NO contact with profile half-cylinder, may be replaced for any profile half-cylinder of a master key system, key only retractable in neutral position, exchange cover, „Ein/Aus“ lettering (German for „On/Off“), aluminium, flush-mounted version: 125 x 100 mm, surface-mounted version: 70 x 90 mm		
				05054731332

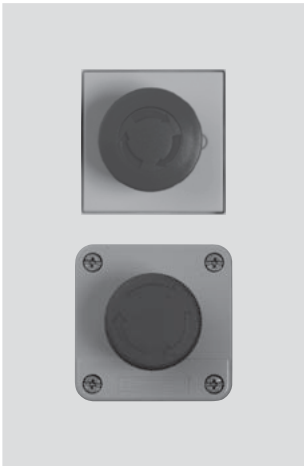

Emergency Push Buttons

	Designation	Specification	Installation system	Order No.
	NAT	Designed to interrupt the automatic movement of the door, emergency pushbutton (function: Emergency Off) for automatic door operators, manufactured to ZH 1/494 or BGR 232, DIN 18650 and EN 16005, red knob with yellow centre insert, max. load current: 10 A at 230 V AC		
	NAT 1	NO contact: 1, NC contact: 1, white frame, flush-mounted version, 80 x 80 mm	System 55	90400025
	NAT 2 no picture	Function "Emergency Opening" with green knob, NO contact: 1, NC contact: 1, max. load current: 10 A at 230 V AC, white frame, flush-mounted version, 80 x 80 mm	System 55	90400035
	NAT 4	NO contact: 1, NC contact: 1, surface-mounted version, 68 x 68 mm		05027031332
	TL-N S55	Highly-illuminated emergency pushbutton environment with visual locking status indication, optical and acoustic alarm via yellow flashlight and integrated alarm siren, sabotage-proof, behind glass, not including frame NO contact: 1, NC contact: 1, max. load current: 1 A at 24 V DC, flush-mounted version, 80 x 80 mm	System 55	56330500



Light Barriers



	Designation	Specification	Order No.
	Prosecure light barrier	Designed to safeguard the passage area of automatic sliding doors via presence detection of moving people and objects (not compliant with DIN 18650 and EN 16005) Counter light barrier comprising transmitter and receiver	86210500

Active infrared detectors

Safety sensors / Combi sensors	Designation	Specification	Colour	Order No.
	Prosecure Opti Scan	The active infrared curtain according EN 16005 ensures optimum protection of the area at the side of the door. It protects people in the danger area of the opening door panel.	black	86301100
			silver coloured	86302100
			white	86303100
	Prosecure Opti Combi	Quick and easy to install, wide field can be used as a light barrier substitute, LCDDisplay, Precise positioning of the AIR curtain thanks to inclination angle display on a clear scale, direction recognition (DIN 18650 and EN 16005)	black	86711400
			silver coloured	86712400
			white	86713400

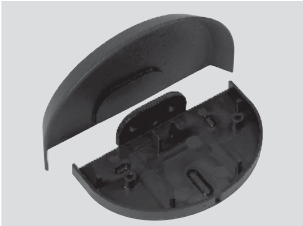
Motion Detectors

	Designation	Specification	Order No.
	Prosecure Easy Motion Mono	Full-automatic access on pulse activation; adjustable inclination angle, inclined field of view and field size, LED status indicator Ambient temperature -20 °C to 60 °C	
		Black	86001000
		Silver-coloured	86002000
		White	86003000
	Prosecure Easy Motion Stereo	Adjustable inclination angle, inclined field of view and field size, direction recognition, cross-traffic suppression, immunity, LED status indicator Ambient temperature -20 °C to 60 °C	
		Black	86011000
	Silver-coloured	86012000	
	White	86013000	
	Prosecure Opti Motion Mono	Adjustable inclination angle, inclined field of view and field size, direction recognition, immunity, LED status indicator Ambient temperature -20 °C to 60 °C	
		Black	86101000
		Silver-coloured	86102000
		White	86103000
	Prosecure Opti Motion Stereo	Adjustable inclination angle, inclined field of view and field size, direction recognition, cross-traffic suppression, Slow Motion function, immunity, LED status indicator Ambient temperature -20 °C to 60 °C	
		Black	86111000
	Silver-coloured	86112000	
	White	86113000	
Accessories	Designation	Specification	Order No.
	Rain protection cover	For Easy Motion detectors	86031900
		Rain protection cover/ ceiling angle bracket	For Opti Motion detectors

Designation	Specification	Order No.
	Rain Protection Cover For all Opti Combi Sensors	86731900
	Ceiling Mounted accessory For all Opti Combi and Opti Scan	Black 86741900 White 86743900

Trims and boxes for surface-mounted pushbuttons and switches

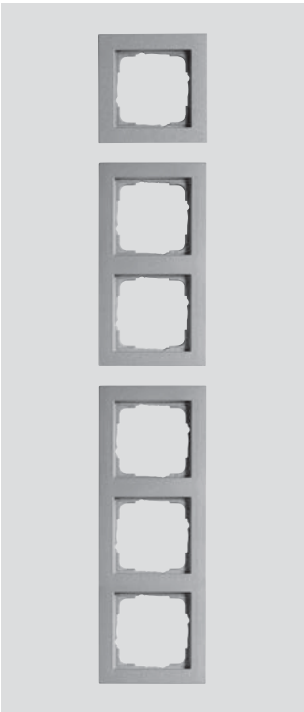
Designation	Specification	Dimensions in mm (W x H x D)	Installation system	Order No.
	System 55 Cover frame (Programm STA)			
FR-S55 1	Single-type trim, Standard 55, white	80.7 x 80.7	System 55	56391110
FR-S55 2	Double-type trim, Standard 55, white	151.8 x 80.7	System 55	56391210
FR-S55 3	Triple-type trim, Standard 55, white	223.3 x 80.7	System 55	56391310
FR-E2W 1	Single-type trim, E2 55, white	80.8 x 80.8	System 55	56392110
FR-E2W 2	Double-type trim, E2 55, white	151.9 x 80.8	System 55	56392210
FR-E2W 3	Triple-type trim, E2 55, white	223.4 x 80.8	System 55	56392310
FR-E2S 1	Single-type trim, E2 55, silver	80.8 x 80.8	System 55	56392101
FR-E2S 2	Double-type trim, E2 55, silver	151.9 x 80.8	System 55	56392201
FR-E2S 3	Triple-type trim, E2 55, silver	223.4 x 80.8	System 55	56392301
FR-E2A 1	Single-type trim, E2 55, anthracite	80.8 x 80.8	System 55	56392115
FR-E2A 2	Double-type trim, E2 55, anthracite	151.9 x 80.8	System 55	56392215
FR-E2A 3	Triple-type trim, E2 55, anthracite	223.4 x 80.8	System 55	56392315

Please see STA price list for further trims and versions.

Middle East and Africa

head office :+971 4 8020 400

United Arab Emirates

Dubai office :+971 4 388 1419

Abu Dhabi office :+971 2 641 9860

Saudi Arabia

Riyadh office :+966 11 464 9586

Damam office :+966 3 864 8261

Jeddah office :+966 12 606 81 77

Kuwait office :+965 2471 6584

Qatar office :+974 4007 0444

South Africa

office :+27 11 510 1500

dormakaba Group
Hofwisenstrasse 24 8153
Rumlang, Switzerland.